

6-port Gigabit POE Switch, 802.3at/bt, 60W/120W

6-Port Gigabit incl 4x30W PoE (port1 40W), 1x1.25G SFP, 1x1000T

POE-GSH411-60 BT | POE-GSH411-120 BT

airlive®

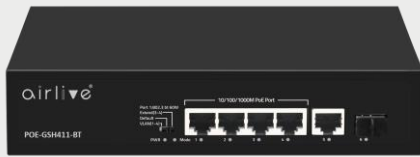

802.3at/bt
30w/40W

Port#1 40W
Hi PoE

Gigabit
RJ45 & SFP

Surge / ESD
protection

Hardware
VLAN

Extend Mode
250m

Plug&Play

Overview

802.3af/at/bt PoE+ Gigabit Switch, with Port#1 Hi PoE 40W

The AirLive POE-GSH411-BT series Gigabit switch is compliant with 802.3af(15W)/802.3at(30W)/802.3bt(40W). It supports four PoE ports and 2 uplink ports either RJ45 or SFP Fiber. Total of PoE power can be 65W or 120W (depended on model). Port 1 supports Hi power PoE up to 40W that satisfy high power needed equipment such as Thin PC, PoE LED, high power IPCAM, etc.

6-Port Gigabit PoE+ Switch with VLAN and SFP/RJ-45 port

The AirLive POE-GSH411-BT series switches are plug and play unmanaged PoE switches with VLAN and 250meter cabling extension, that you can set easily be set by its DIP switch. The two Gigabit Uplink ports (1x SFP and 1x RJ-45) help with connecting the switch to a larger network making the it the most cost-efficient client switch for various applications at Home or Office.

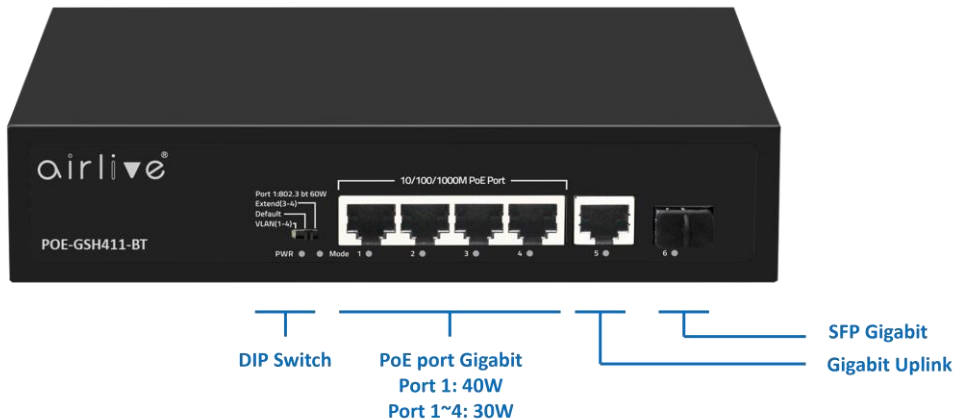

Features

- All 6-port, each port delivers Gigabit high speed
- 4 x PoE port (up to 30W, Port #1 up to 40W), 2 x Uplink Port
- Extend the network further with 1 SFP slot that accept fiber transceivers and go beyond the limits of Ethernet
- PoE power, supports 802.3at/802.3bt PoE+ / PoE++
- Internal Power, 65W or 120W
- VLAN Mode, Extended Mode: transmission of up to 250M in Extend Mode Setting by hardware DIP switch
- Surge Protection; ESD Protection
- Model numbers:
 - ✓ **POE-GSH411-60-BT**: 4 x PoE 10/100/1000 (Port#1 up to 40W), 1 x 1000T, 1 x 1G SFP slot, 65W
 - ✓ **POE-GSH411-120-BT**: 4 x PoE 10/100/1000 (Port#1 up to 40W), 1 x 1000T, 1 x 1G SFP slot, 120W

Efficient PoE technology BT Hi Power and AT PoE.

Connect several PoE devices to the switch, Port 1 of the switch can power devices up to 40W. 40W can be used by high power IP camera or by PoE Led, thin clients. Giving you much more flexibility on the usage, as you are no longer restricted to only 30W. Other devices like Access Points or normal IP cameras can connect to any of the PoE ports on the switch and by power on up to max 30W (at).

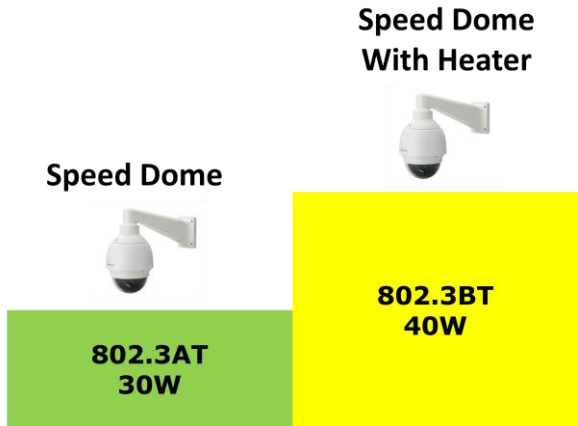

VLAN and Extend Mode

The POE-GSH411-BT switch can be set in Extend mode to reach a distance of up to 250m, this can be very useful in locations where it hard to get power to turn on your PD device. The Extend mode makes this easier. The Extend mode is only for Port 3 and 4 on the switch and when enabled the transmission rate will be 10Mbps.

VLAN mode: When the Port Isolation mode is enabled the PoE ports (1~4) cannot communicate with each other and can only communicate with the UP-Link port.

Fiber backbone for Long Distance and Interconnect between floors

Extend the network further with SFP slot. Use the POE-GSH411-BT fiber port to connect different floors together in a large building or to the main office over a longer distance. Depending on the module used it can reach up to 20KM in speed of 1250Mbps data transmission.

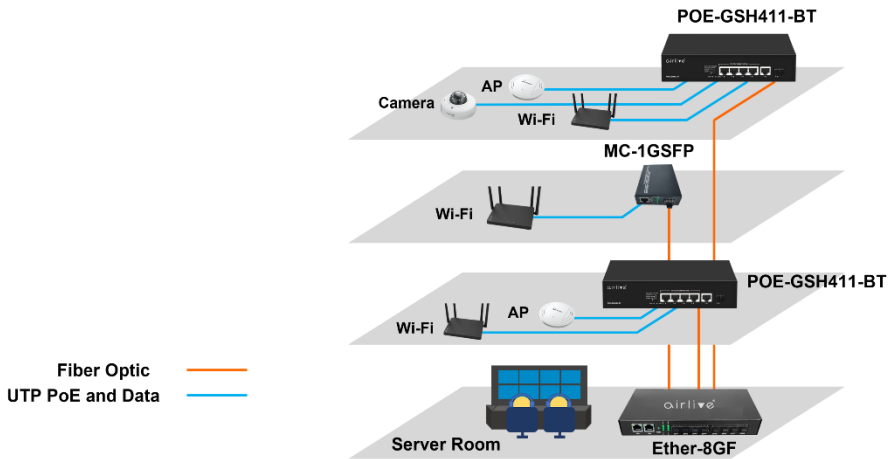

Model	AirLive POE-GSH411-BT series
<p>Hardware</p> <ul style="list-style-type: none"> • Device Interface: 4 x 30W PoE 10/100/1000 RJ45, Port#1 up to 40W 1 x Uplink Gigabit port RJ45 1 x Uplink Gigabit SFP • Standard IEEE802.3u 100Base-TX / 100Base-FX IEEE802.3ab Gigabit 1000Base-T IEEE802.3z Gigabit SX/LX (optical fiber) IEEE802.3at/af/bt PoE IEEE802.3x IEEE802.3az Energy Efficient Ethernet • Industry standard compliant EMI: FCC Part 15 CISPR (EN55032) class A EMS: EN61000-4-2 (ESD), EN61000-4-4(EFT), EN61000-4-5(Surge) Shock: IEC 60068-2-27 Free Fall: IEC 60068-2-32 Vibration: IEC 60068-2-6 • LED Indicators: PWR (power supply) Mode (DIP): VLAN, Default, Extend Link and Data • Mechanical Metal <p>Power and PoE</p> <ul style="list-style-type: none"> • Protocol: IEEE802.3bt (40W), IEEE802.3at (30W), IEEE802.3af (15.4W) • PoE Port: 4 • PoE Power Output / PoE Port: max. 40 watts (Port #1) and max. 30W (port 2~4) • PoE Power/ Switch: 65W or 120W (depends on model) <p>Surge and ESD protection 4KV (Surge), 8KV (EDS)</p> <p>Switch Architecture Performance</p> <ul style="list-style-type: none"> • Fiber Medium Multi-mode Fiber: 850nm, 1310nm Transmission Distance: 550m/2Km Single-mode Fiber: 1310nm, 1550nm Transmission Distance 20/40/60/80/Km • Switching architecture: Store and Forward Switch Capacity: Back-plan up to 12Gbps Forwarding Rate; 8.928Mpps MAC Address: 2K Packet Buffer: 1Mb Jumbo Frame: 9216bytes Transfer mode: Store and forward MTBF:100000 hour 	<p>DIP Switch Control</p> <ul style="list-style-type: none"> • VLAN: Port isolation mode. In this mode PoE ports (1~4) cannot communicate with each other and can only communicate with the UP-Link port, • Default: Normal mode, all port can communicate with each other, the transmission distance is within 100m, the transmission rate is 10M/100/1000M adaptive • Extend: Extension mode, PoE power supply and data transmission distance can be extended to 250 meter at the transmission rate 10Mbps Port 3~4 only. <p>Power Supply</p> <ul style="list-style-type: none"> • Input Voltage: AC100~240V • Power Supply: 52V/2.3A (120W) or 52V/1.25A 65W <p>Environment</p> <ul style="list-style-type: none"> • Operating Temperature: -10°C~+50°C • Storage Temperature: -40°C~+85°C • Humidity: 5%~95%, non-condensing <p>Standard package of switch</p> <ul style="list-style-type: none"> • Product size: 20 x 11.8 x 4.4 cm(L*W*H) • Package size: 24.5 x 19 x 6cm(L*W*H) • Product Weight/Package Weight NW: 0.6kg; G.W:0.9kg • Package content: 1 x Switch, 1 x Power Cord. <p>Standard carton package</p> <ul style="list-style-type: none"> • Quantity: 20 pcs / 1 carton • Dimensions 50.5 x 32 x 40.2 cm • Carton Weight 19Kgs <p>Ordering Information</p> <ul style="list-style-type: none"> • Model: POE-GSH411 BT series: <u>POE-GSH411-60 BT:</u> 4 x PoE 10/100/1000 (Port#1 up to 40W), 1 x 1000T, 1 x 1G SFP slot, 65W <u>POE-GSH411-120 BT:</u> 4 x PoE 10/100/1000 (Port#1 up to 40W), 1 x 1000T, 1 x 1G SFP slot, 120W

* Specification will be changed without prior notice

